

SF1 Filter – Miniature

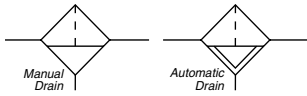

Features

- Stainless Steel Construction handles most corrosive environments.
- Fluorocarbon seals standard.
- Meets NACE specifications.
- High Flow: 1/4" – 23 SCFM[§]

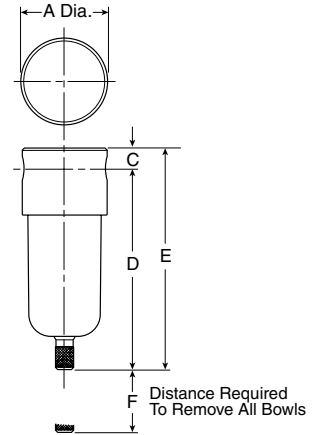

Port Size	NPT	BSPB
	Manual Drain	Manual Drain
1/4"	SF1-02-SYV0	SF1-C2-SYV0

SF1 Filter Dimensions		
A	C	D
1.56 40 mm	0.31 8 mm	3.69 94 mm
E	F	
4.00 102 mm	1.58 40 mm	

Standard part numbers shown, for other models refer to ordering information below.

[§] SCFM = Standard cubic feet per minute at 90 PSIG inlet and 5 PSIG pressure drop.

Ordering Information

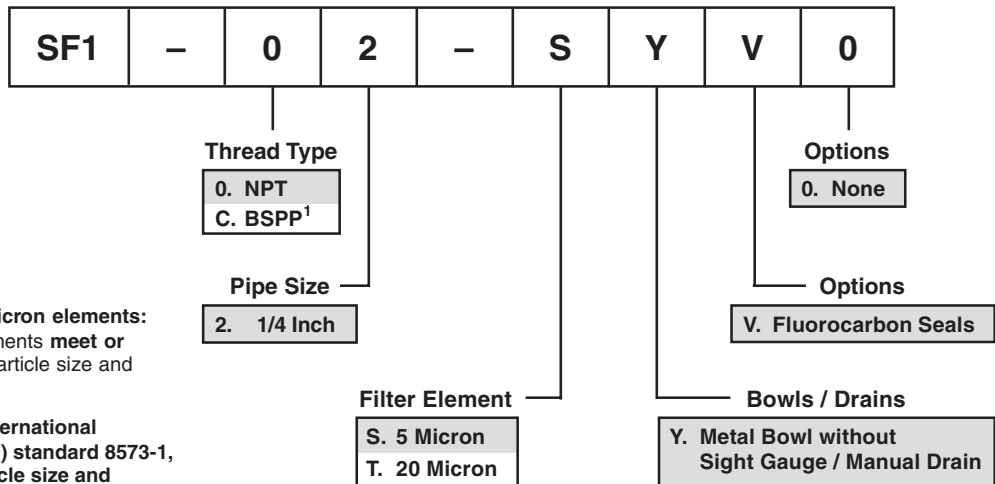

¹ ISO, R228 (G SERIES)

“SF” Series Filters, Type “A” 5 micron elements:
 All Wilkerson Type “A” 5 micron elements **meet or exceed** ISO Class 3 for maximum particle size and concentration of solid contaminants.

NOTE: All classes above refer to International Standards Organization (ISO) standard 8573-1, pertaining to maximum particle size and concentration of solid contaminants, and maximum oil content.

NOTE: Shaded = “Most Popular”.

Operation

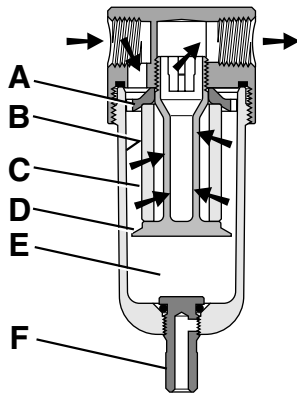

First Stage Filtration:

Air enters at inlet port and flows through deflector plate (A) which causes a swirling action. Liquids and coarse particles are forced to the bowl interior wall (B) by the centrifugal action of the swirling air. They are then carried down the bowl wall by the force of gravity. The baffle (D) separates the lower portion of the bowl into a “quiet zone” (E) where the removed liquid and particles collect, unaffected by the swirling air, and are therefore not reentrained into the flowing air.

Second Stage Filtration:

After liquids and large particles are removed in the first stages of filtration, the air flows through element (C) where smaller particles are filtered out. The filtered air then passes downstream. Collected liquids and particles in the “quiet zone” (E) should be drained before their level reaches a height where they would be reentrained in the flowing air. This can be accomplished by unscrewing the drain valve (F) slightly until the liquid begins to drain.

Technical Information

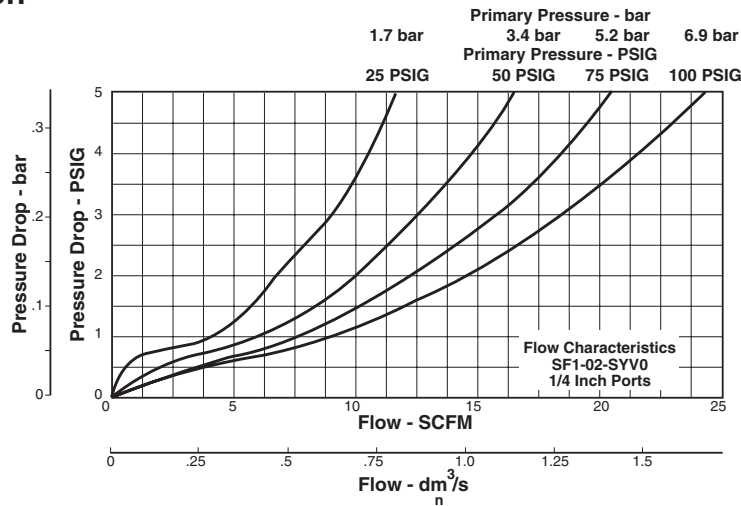

SF1 Filter Kits & Accessories

- Filter Element Kits –**
 - Particulate (5 Micron) SRP-96-001
 - Particulate (20 Micron) SRP-96-002
- Manual Drain –** SRP-96-008
- Pipe Nipple – 1/4" 316 Stainless Steel** SRP-96-009

Specifications

- Bowl Capacity** 1.0 Ounces
- Filter Rating** 5 Micron
- Useful Retention†** 0.4 Ounce
- Port Threads** 1/4 Inch
- Pressure & Temperature Ratings** 0 to 300 PSIG (0 to 20.7 bar)
 40°F to 180°F (4°C to 82°C)
- Weight** 0.6 lb. (0.27 kg)

Materials of Construction

- Body** 316 Stainless Steel
- Bowl** 316 Stainless Steel
- Drain** 316 Stainless Steel
- Filter Element** Polyethylene
- Element Holder** Acetal
- Seals** Fluorocarbon
- Deflector** Acetal

† Useful Retention refers to volume below the quiet zone baffle.

SF2 Filter – Standard

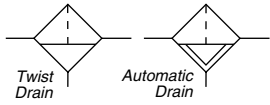

Features

- Stainless Steel Construction handles most corrosive environments.
- Meets NACE specifications.
- High Flow: 1/2" – 70 SCFM[§]

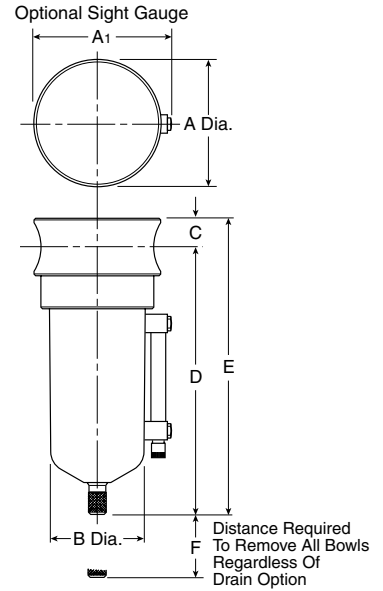

Port Size	NPT		BSPP	
	Manual Drain	Auto Float Drain	Manual Drain	Auto Float Drain
1/2"	SF2-04-SYV0	SF2-04-SXV0	SF2-C4-SYV0	SF2-C4-SXV0

SF2 Filter Dimensions		
A 2.38 60 mm	A₁ 2.50 64 mm	B 1.75 44 mm
C 0.56 14 mm	D 5.00 127 mm	E 5.56 141 mm
F 2.12 54 mm		

Standard part numbers shown, for other models refer to ordering information below.
[§] SCFM = Standard cubic feet per minute at 90 PSIG inlet and 5 PSIG pressure drop.

Ordering Information

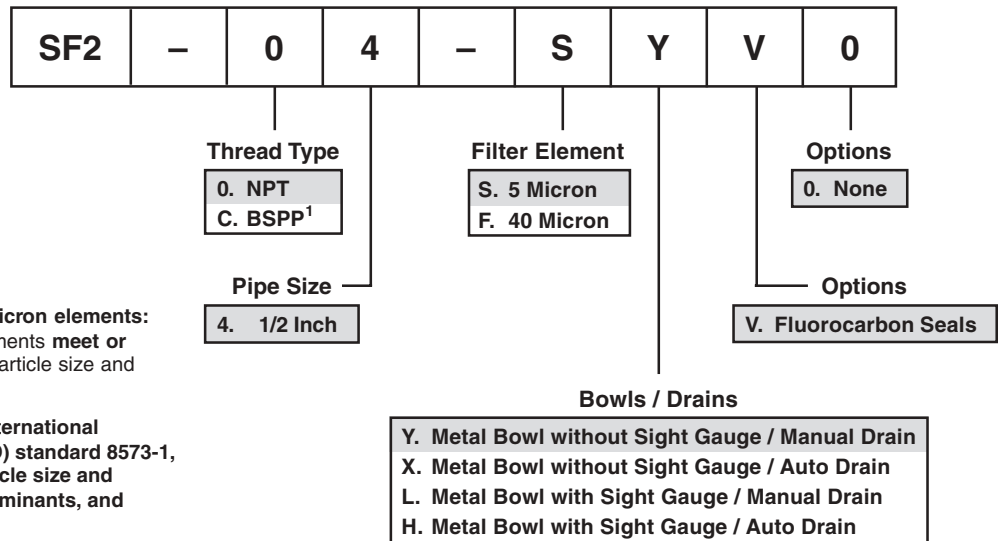

¹ ISO, R228 (G SERIES)

“SF” Series Filters, Type “A” 5 micron elements:
 All Wilkerson Type “A” 5 micron elements meet or exceed ISO Class 3 for maximum particle size and concentration of solid contaminants.

NOTE: All classes above refer to International Standards Organization (ISO) standard 8573-1, pertaining to maximum particle size and concentration of solid contaminants, and maximum oil content.

NOTE: Shaded = “Most Popular”.

Operation

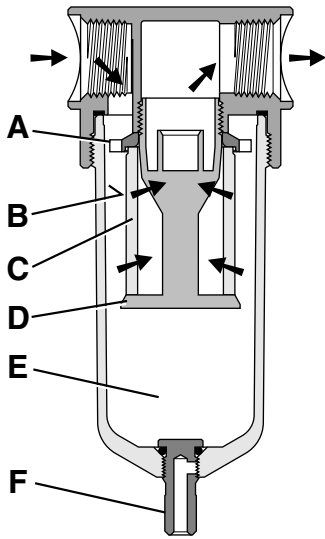

First Stage Filtration:

Air enters at inlet port and flows through deflector plate (A) which causes a swirling action. Liquids and coarse particles are forced to the bowl interior wall (B) by the centrifugal action of the swirling air. They are then carried down the bowl wall by the force of gravity. The baffle (D) separates the lower portion of the bowl into a “quiet zone” (E) where the removed liquid and particles collect, unaffected by the swirling air, and are therefore not reentrained into the flowing air.

Second Stage Filtration:

After liquids and large particles are removed in the first stages of filtration, the air flows through element (C) where smaller particles are filtered out. The filtered air then passes downstream. Collected liquids and particles in the “quiet zone” (E) should be drained before their level reaches a height where they would be reentrained in the flowing air. This can be accomplished by unscrewing the drain valve (F) slightly until the liquid begins to drain.

Technical Information

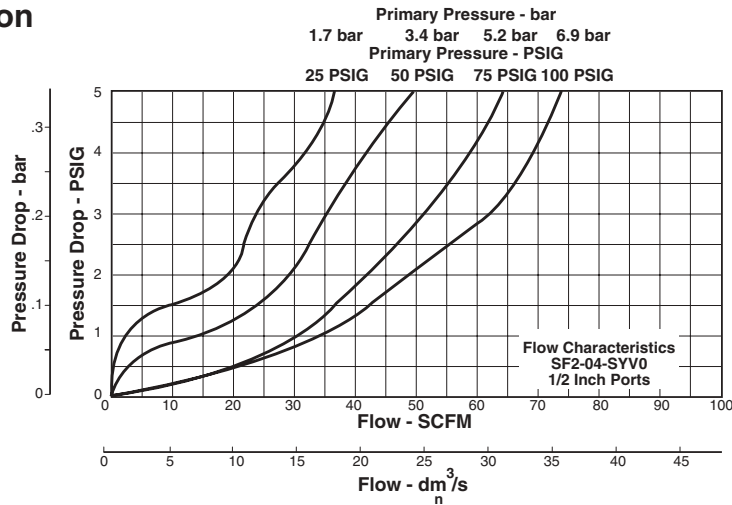

SF2 Filter Kits & Accessories

Drain Kit – Automatic Drain	SRP-96-007
Manual Drain	SRP-96-008
Filter Element Kits – Particulate (40 Micron)	SRP-96-004
Particulate (5 Micron)	SRP-96-003
Liquid Level Sight Gauge Kit	SRP-96-026
Pipe Nipple – 1/2" 316 Stainless Steel	SRP-96-010

Specifications

Body Capacity	4.0 Ounces
Filter Rating	5 Micron
Useful Retention [†]	1.7 Ounce
Port Threads	1/2 Inch
Pressure & Temperature Ratings –	
Manual Drain – 0 to 300 PSIG (0 to 20.7 bar)	
40°F to 180°F (4°C to 82°C)	
Automatic Drain – 15 to 175 PSIG (1 to 12 bar)	
40°F to 120°F (4°C to 49°C)	
Weight	1.9 lb. (0.85 kg)

Materials of Construction

Body	316 Stainless Steel
Bowl	316 Stainless Steel
Drain	316 Stainless Steel
Filter Element	Polyethylene
Element Holder	Acetal
Seals	Fluorocarbon
Deflector	Acetal

[†] Useful Retention refers to volume below the quiet zone baffle.

SM1 Coalescing Filter – Miniature

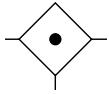

Features

- Stainless Steel Construction handles most corrosive environments.
- Meets NACE specifications.
- High Flow: 1/4" – 16 SCFM[§]

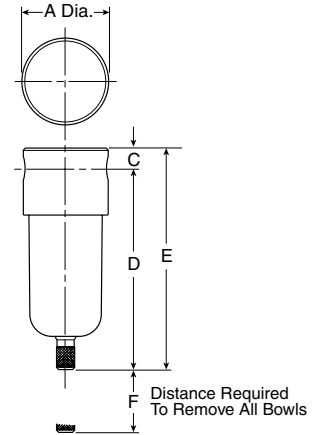

Port Size	NPT	BSP
	Manual Drain	Manual Drain
1/4"	SM1-02-EYV0	SM1-C2-EYV0

SM1 Coalescing Filter Dimensions		
A	C	D
1.56 40 mm	0.31 8 mm	3.69 94 mm
E	F	
4.00 102 mm	1.58 40 mm	

Standard part numbers shown, for other models refer to ordering information below.
[§] SCFM = Standard cubic feet per minute at 90 PSIG inlet and 5 PSIG pressure drop.

Ordering Information

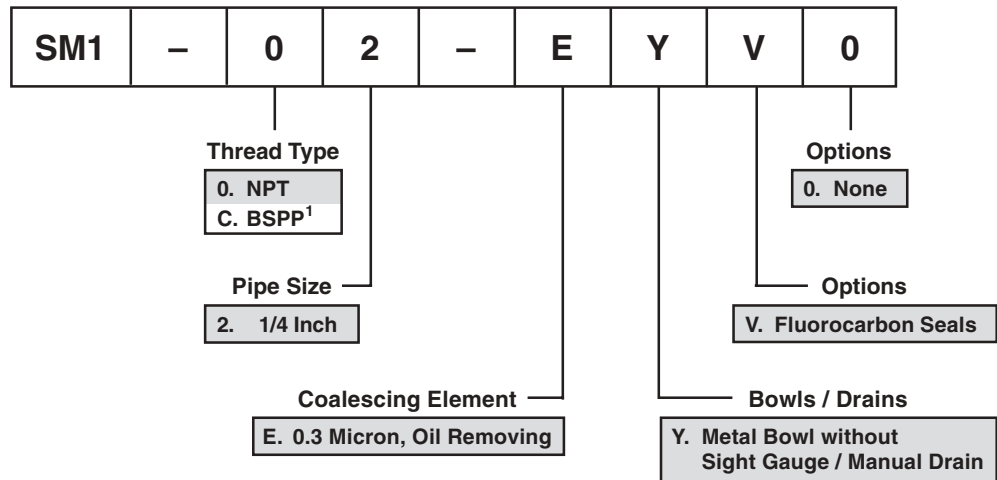

¹ ISO, R228 (G SERIES)

NOTE: Shaded = "Most Popular".

Operation

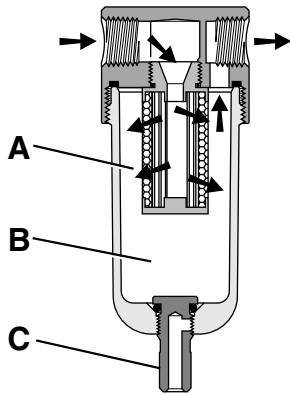

The contaminated air enters the element interior and is forced through a thick membrane (A) of “borosilicate” glass fibers coated with epoxy. Flow then passes through the element, and at this stage 99.97% of the sub micron particles have been removed from the air stream. The tiny droplets coalesce together and are collected from the filter element by the outer drain layer.

The clean, filtered air now passes through and out into the pneumatic system. The air line coalescing filter removes liquid aerosols and sub-micron particulate matter.

Collected liquids and particles in the “quiet zone” (B) should be drained before their level reaches a height where they would be reentrained in the flowing air. This can be accomplished by unscrewing the drain valve (C) slightly until the liquid begins to drain.

Technical Information

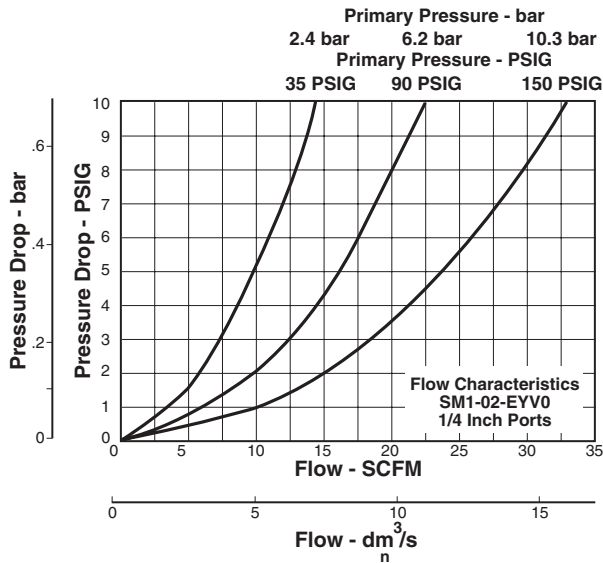

SM1 Filter Kits & Accessories

- Filter Element Kits – 0.3 Micron SRP-96-005
- Manual Drain SRP-96-008
- Pipe Nipple – 1/4" 316 Stainless Steel SRP-96-009

Specifications

- Bowl Capacity 1.0 Ounces
- Filter Rating 0.3 Micron
- Useful Retention† 0.4 Ounce
- Port Threads 1/4 Inch
- Pressure & Temperature Ratings 0 to 300 PSIG (0 to 20.7 bar)
 40°F to 180°F (4°C to 82°C)
- Weight 0.6 lb. (0.27 kg)

Materials of Construction

- Body 316 Stainless Steel
- Bowl 316 Stainless Steel
- Drain (Manual) 316 Stainless Steel
- Filter Element Borosilicate Fiber
- Element Holder Acetal
- Seals Fluorocarbon

† Useful Retention refers to volume below the quiet zone baffle.

SM2 Coalescing Filter – Standard

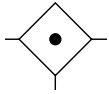

Features

- Stainless Steel Construction handles most corrosive environments.
- Meets NACE specifications.
- High Flow: 1/2" – 45 SCFM[§]

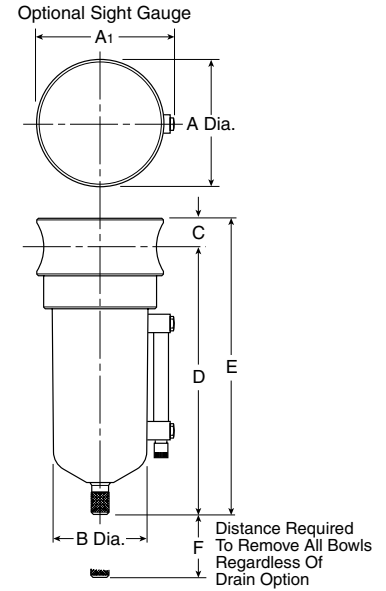

Port Size	NPT		BSPP	
	Manual Drain	Auto Float Drain	Manual Drain	Auto Float Drain
1/2"	SM2-04-EYV0	SM2-04-EXV0	SM2-C4-EYV0	SM2-C4-EXV0

SM2 Coalescing Filter Dimensions		
A 2.38 60 mm	A₁ 2.50 64 mm	B 1.75 44 mm
C 0.56 14 mm	D 5.00 127 mm	E 5.56 141 mm
F 2.12 54 mm		

Standard part numbers shown, for other models refer to ordering information below.

[§] SCFM = Standard cubic feet per minute at 90 PSIG inlet and 5 PSIG pressure drop.

Ordering Information

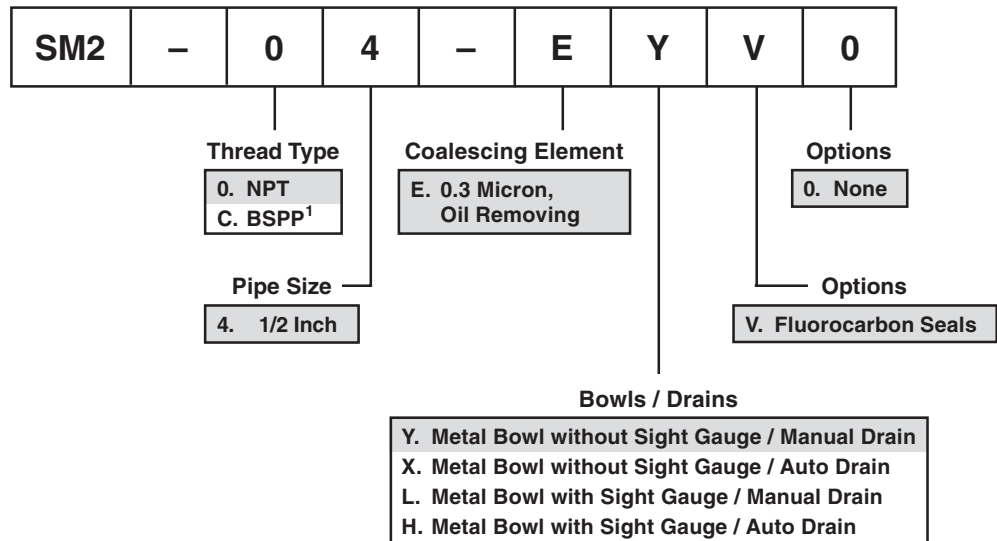

¹ ISO, R228 (G SERIES)

NOTE: Shaded = "Most Popular".

Operation

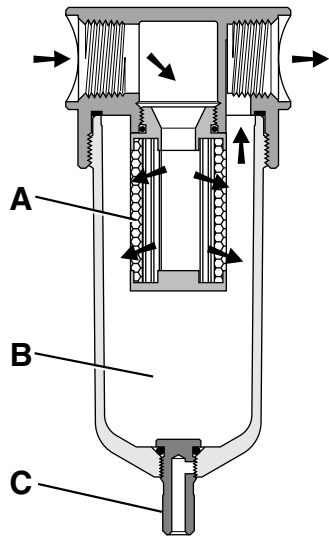

The contaminated air enters the element interior and is forced through a thick membrane (A) of “borosilicate” glass fibers coated with epoxy. Flow then passes through the element, and at this stage 99.97% of the sub micron particles have been removed from the air stream. The tiny droplets coalesce together and are collected from the filter element by the outer drain layer.

The clean, filtered air now passes through and out into the pneumatic system. The air line coalescing filter removes liquid aerosols and sub-micron particulate matter.

Collected liquids and particles in the “quiet zone” (B) should be drained before their level reaches a height where they would be reentrained in the flowing air. This can be accomplished by unscrewing the drain valve (C) slightly until the liquid begins to drain.

Technical Information

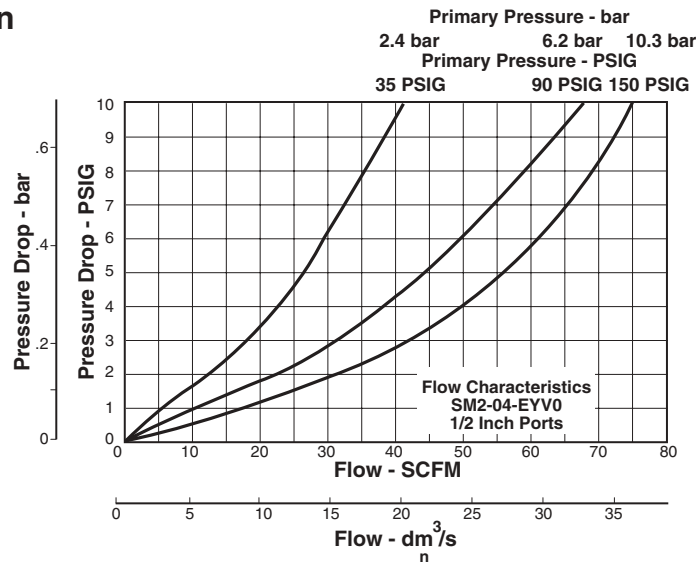

SM2 Filter Kits & Accessories

- Drain Kit – Automatic Drain SRP-96-007
- Manual Drain SRP-96-008
- Filter Element Kits – 0.3 Micron SRP-96-006
- Liquid Level Sight Gauge Kit SRP-96-026
- Pipe Nipple – 1/2" 316 Stainless Steel SRP-96-010

Specifications

- Bowl Capacity 4.0 Ounces
- Filter Rating 0.3 Micron
- Useful Retention† 1.7 Ounce
- Port Threads 1/2 Inch
- Pressure & Temperature Ratings –
 - Manual Drain – 0 to 300 PSIG (0 to 20.7 bar)
 - 40°F to 180°F (4°C to 82°C)
 - Automatic Drain – 0 to 175 PSIG (0 to 12 bar)
 - 40°F to 120°F (4°C to 49°C)
- Weight 1.9 lb. (0.85 kg)

Materials of Construction

- Body 316 Stainless Steel
- Bowl 316 Stainless Steel
- Drain 316 Stainless Steel
- Filter Element Borosilicate Fiber
- Element Holder Acetal
- Seals Fluorocarbon

† Useful Retention refers to volume below the quiet zone baffle.

SR1 Regulator – Miniature

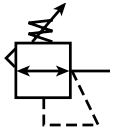

Features

- Stainless Steel Construction handles most corrosive environments.
- Large diaphragm to valve area ratio for precise regulation and high flow capacity.
- Meets NACE specifications.
- High Flow: 1/4" – 12 SCFM[§]

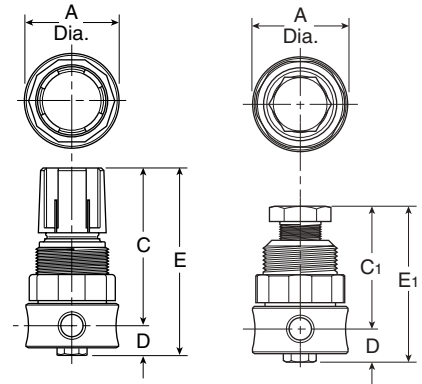

Port Size	NPT	BSPP
1/4"	SR1-02-LA00	SR1-C2-LA00

SR1 Regulator Dimensions		
A	C	C1
1.56 40 mm	2.56 65 mm	2.17 55 mm
D	E	E1
0.50 13 mm	3.06 78 mm	2.67 68 mm

Standard part numbers shown, for other models refer to ordering information below.
[§] SCFM = Standard cubic feet per minute at 100 PSIG inlet, 75 PSIG no flow secondary setting and 25% pressure drop.

Ordering Information

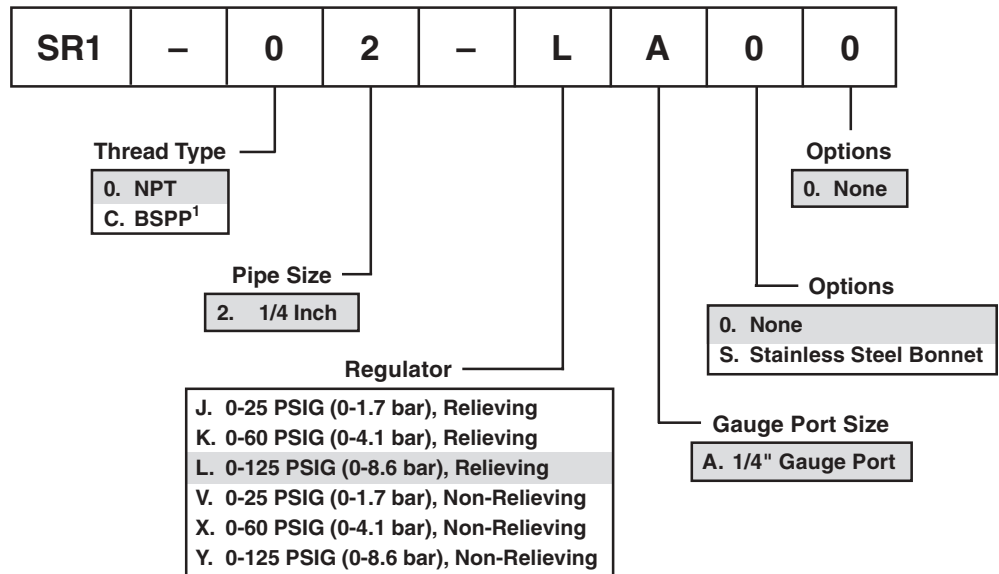

¹ ISO, R228 (G SERIES)

NOTE: Shaded = "Most Popular".

SR2 Regulator – Standard

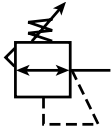

Features

- Stainless Steel Construction handles most corrosive environments.
- Large diaphragm to valve area ratio for precise regulation and high flow capacity.
- Meets NACE specifications.
- High Flow: 1/2" – 80 SCFM[§]

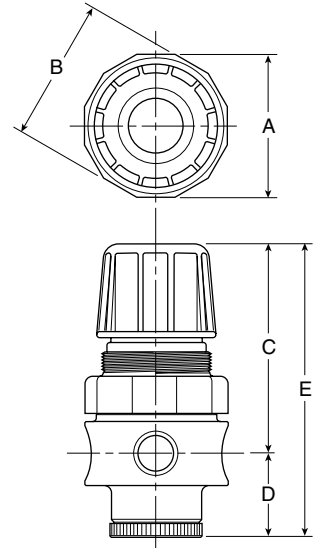

Port Size	NPT	BSPP
1/2"	SR2-04-LA00	SR2-C4-LA00

SR2 Regulator Dimensions		
A	B	C
2.34 60 mm	2.43 62 mm	3.59 91 mm
D	E	
1.38 35 mm	4.97 126 mm	

Standard part numbers shown, for other models refer to ordering information below.

[§] SCFM = Standard cubic feet per minute at 100 PSIG inlet, 75 PSIG no flow secondary setting and 25% pressure drop.

Ordering Information

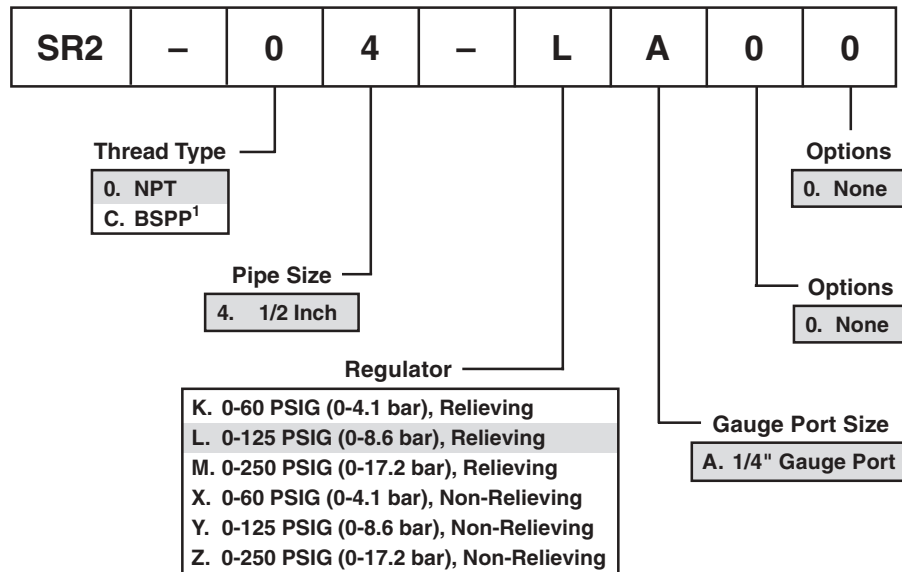

¹ ISO, R228 (G SERIES)

NOTE: Shaded = "Most Popular".

SB1 Filter / Regulator – Miniature

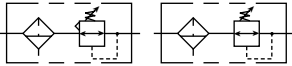

Features

- Stainless Steel Construction handles most corrosive environments.
- Large diaphragm to valve area ratio for precise regulation and high flow capacity.
- Meets NACE specifications.
- High Flow: 1/4" – 12 SCFM[§]

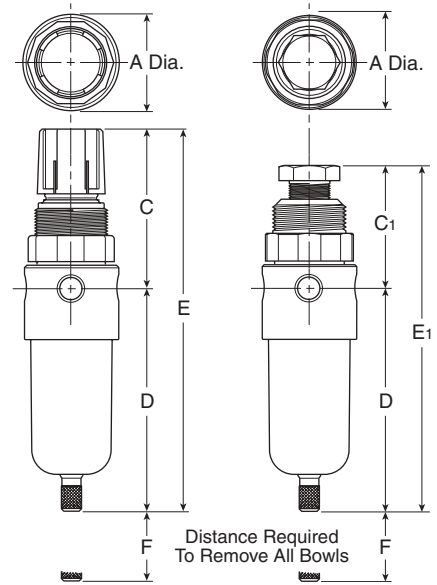

Port Size	NPT	BSP
1/4"	SB1-02-LYS0	SB1-C2-LYS0

SB1 Piggyback Dimensions		
A 1.56 40 mm	C 2.63 67 mm	C1 2.17 55 mm
D 3.63 92 mm	E 6.25 159 mm	E1 5.80 147 mm
F 1.58 40 mm		

Standard part numbers shown, for other models refer to ordering information below.
[§] SCFM = Standard cubic feet per minute at 100 PSIG inlet, 75 PSIG no flow secondary setting and 25% pressure drop.

Ordering Information

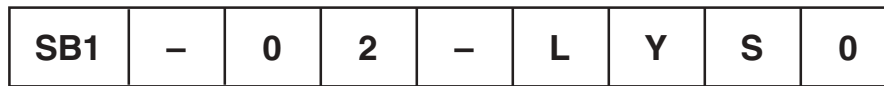

¹ ISO, R228 (G SERIES)

“SB” Series Filters / Regulators, Type “A” 5 micron elements: All Wilkerson Type “A” 5 micron elements meet or exceed ISO Class 3 for maximum particle size and concentration of solid contaminants.

NOTE: All classes above refer to International Standards Organization (ISO) standard 8573-1, pertaining to maximum particle size and concentration of solid contaminants, and maximum oil content.

NOTE: Shaded = “Most Popular”.

Thread Type

- 0. NPT
- C. BSPP¹

Pipe Size

- 2. 1/4 Inch

Filter / Regulator Combo

- J. 0-25 PSIG (0-1.7 bar), Relieving
- K. 0-60 PSIG (0-4.1 bar), Relieving
- L. 0-125 PSIG (0-8.6 bar), Relieving
- V. 0-25 PSIG (0-1.7 bar), Non-Relieving
- X. 0-60 PSIG (0-4.1 bar), Non-Relieving
- Y. 0-125 PSIG (0-8.6 bar), Non-Relieving

Options

- 0. None
- S. Stainless Steel Bonnet

Options

- S. 5 Micron
- T. 20 Micron

Bowls / Drains

- Y. Metal Bowl without Sight Gauge / Manual Drain

Operation

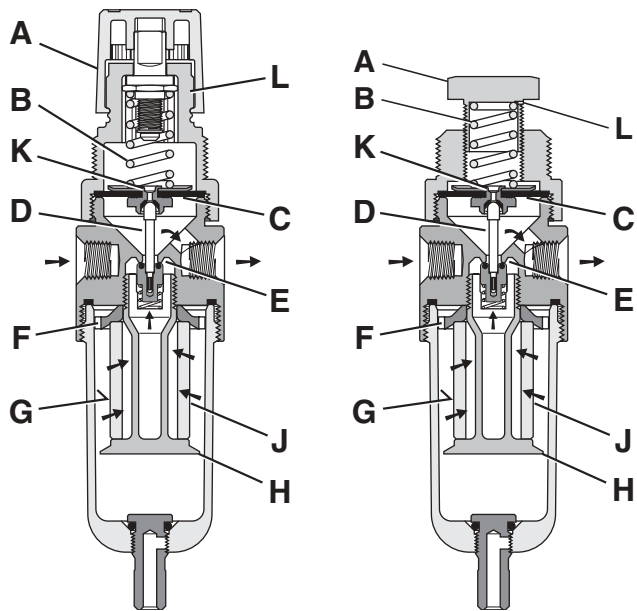

Turning the adjusting knob clockwise applies a load to control spring (B) which forces diaphragm (C) and valve poppet assembly (D) to move downward allowing filtered air to flow through the seat area (E) created between the poppet assembly and the seat. **“First stage filtration”**. Air pressure supplied to the inlet port is directed through deflector plate (F) causing a swirling centrifugal action forcing liquids and coarse particles to the inner bowl wall (G) and down below the lower baffle (H) to the quiet zone. After liquids and large particles are removed in the first stage of filtration **“second stage filtration”** occurs as air flows through element (J) where smaller particles are filtered out and retained. The air flow now passes through seat area (E) to the outlet port of the unit. Pressure in the downstream line is sensed below the diaphragm (C) and offsets the load of spring (B). When downstream pressure reaches the set-point, poppet valve assembly (D) and diaphragm (C) move upward closing seat area (E). Should downstream pressure exceed the desired regulated pressure, the excess pressure will cause the diaphragm (C) to move upward opening vent hole (K) venting the excess pressure to atmosphere through the hole in the bonnet (L). (This occurs in the standard relieving type filter/regulators only.)

⚠ WARNING

Product rupture can cause serious injury.
Do not connect regulator to bottled gas.
Do not exceed maximum primary pressure rating.

Technical Information

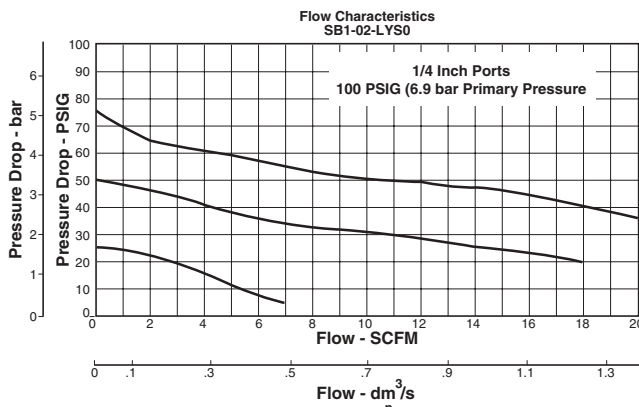

SB1 Regulator Kits & Accessories

- Bonnet Kit (Black Knob Included) SRP-96-017
- Filter Element Kits –
 - Particulate (5 Micron) SRP-96-001
 - Particulate (20 Micron) SRP-96-002
- Gauge – 0 to 160 PSIG (0 to 1100 kPa) SRP-96-021
- Manual Drain SRP-96-008
- Panel Mount Nut SRP-96-019
- Pipe Nipple – 1/4" 316 Stainless Steel SRP-96-009
- Service Kit – Relieving SRP-96-015
- Non-Relieving SRP-96-016

- Filter Rating 5 Micron
- Gauge Port 1/4 Inch
- Port Threads 1/4 Inch
- Pressure & Temperature Ratings – 300 PSIG Max (20.7 bar)
40°F to 150°F (4°C to 66°C)
- Useful Retention† 0.4 Ounce
- Weight 0.8 lb. (0.36 kg)

Specifications

Bowl Capacity 1.0 Ounces

Note: Order pressure gauge and panel mount nut separately.
Note: 1.19" dia. (30.2 mm) hole required for panel mounting (order panel nut separately).

† Useful Retention refers to volume below the quiet zone baffle.

Materials of Construction

- Body 316 Stainless Steel
- Bowl 316 Stainless Steel
- Drain 316 Stainless Steel
- Filter Elements (Type A) Polyethylene
- Element Holder / Deflector / Bonnet Acetal
- Diaphragm and Seals Fluorocarbon
- Valve Assembly and Bottom Plug 316 Stainless Steel
- Springs 316 Stainless Steel
- Knob Polypropylene

SB2 Filter / Regulator – Standard

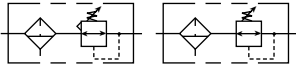

Features

- Stainless Steel Construction handles most corrosive environments.
- Large diaphragm to valve area ratio for precise regulation and high flow capacity.
- Meets NACE specifications.
- High Flow: 1/2" – 72 SCFM[§]

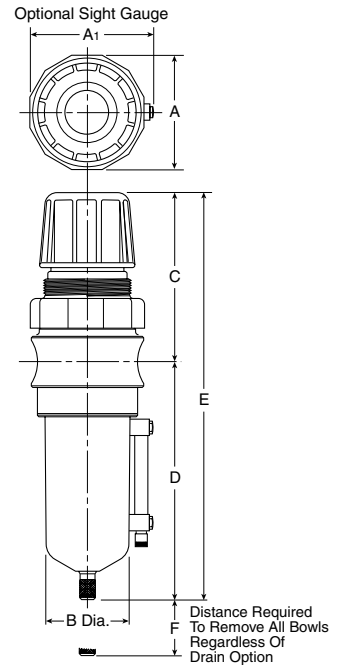

Port Size	NPT	BSPP
1/2"	SB2-04-LYS0	SB2-C4-LYS0

SB2 Piggyback Dimensions		
A	A1	B
2.34 60 mm	2.50 64 mm	1.75 44 mm
C	D	E
3.59 91 mm	5.00 127 mm	8.59 218 mm
F		
2.12 54 mm		

Standard part numbers shown, for other models refer to ordering information below.
[§] SCFM = Standard cubic feet per minute at 100 PSIG inlet, 75 PSIG no flow secondary setting and 25% pressure drop.

Ordering Information

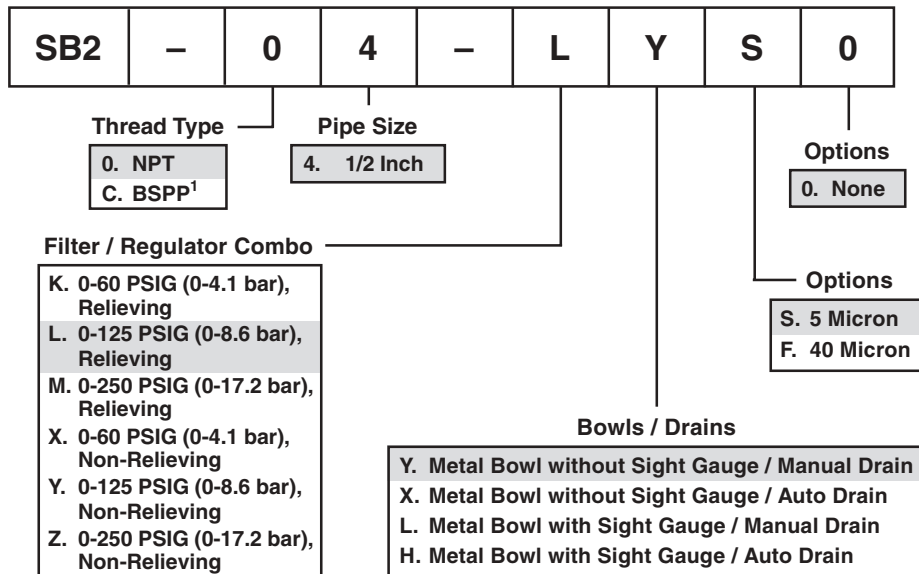

¹ ISO, R228 (G SERIES)

“SB” Series Filters / Regulators, Type “A” 5 micron elements: All Wilkerson Type “A” 5 micron elements meet or exceed ISO Class 3 for maximum particle size and concentration of solid contaminants.

NOTE: All classes above refer to International Standards Organization (ISO) standard 8573-1, pertaining to maximum particle size and concentration of solid contaminants, and maximum oil content.

NOTE: Shaded = “Most Popular”.

Operation

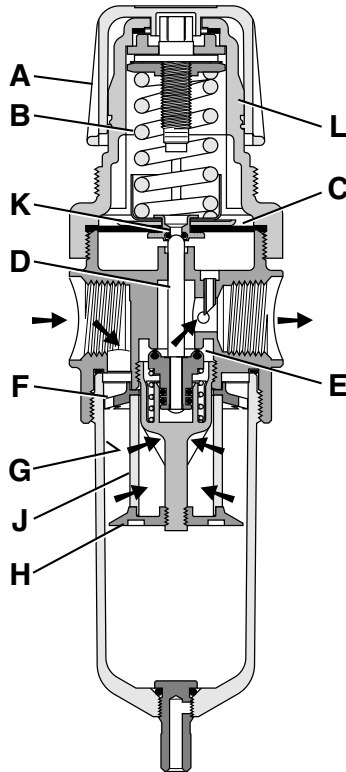

Turning the adjusting knob clockwise applies a load to control spring (B) which forces diaphragm (C) and valve poppet assembly (D) to move downward allowing filtered air to flow through the seat area (E) created between the poppet assembly and the seat. “First stage filtration”. Air pressure supplied to the inlet port is directed through deflector plate (F) causing a swirling centrifugal action forcing liquids and coarse particles to the inner bowl wall (G) and down below the lower baffle (H) to the quiet zone. After liquids and large particles are removed in the first stage of filtration “second stage filtration” occurs as air flows through element (J) where smaller particles are filtered out and retained. The air flow now passes through seat area (E) to the outlet port of the unit. Pressure in the downstream line is sensed below the diaphragm (C) and offsets the load of spring (B). When downstream pressure reaches the set-point, poppet valve assembly (D) and diaphragm (C) move upward closing seat area (E). Should downstream pressure exceed the desired regulated pressure, the excess pressure will cause the diaphragm (C) to move upward opening vent hole (K) venting the excess pressure to atmosphere through the hole in the bonnet (L). (This occurs in the standard relieving type filter/regulators only.)

WARNING

Product rupture can cause serious injury.

Do not connect regulator to bottled gas.

Do not exceed maximum primary pressure rating.

Technical Information

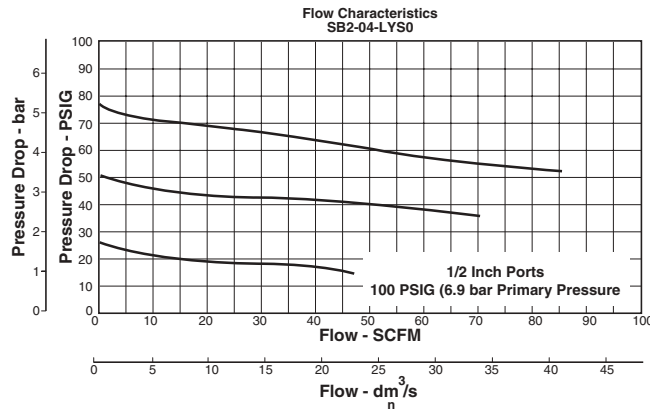

SB2 Regulator Kits & Accessories

Bonnet Kit (Knob Included)	SRP-96-018
Filter Element Kits –	
Particulate (5 Micron)	SRP-96-003
Particulate (40 Micron)	SRP-96-004
Gauge – 0 to 160 PSIG (0 to 1100 kPa)	SRP-96-022
Liquid Level Sight Gauge Kit	SRP-96-026
Automatic Drain	SRP-96-007
Manual Drain	SRP-96-008
Panel Mount Nut	SRP-96-020
Pipe Nipple – 1/2" 316 Stainless Steel	SRP-96-010
Service Kit – Relieving	SRP-96-011
Non-Relieving	SRP-96-012

Note: Order pressure gauge and panel mount nut separately.
 Note: 1.75" dia. (44.5 mm) hole required for panel mounting (order panel nut separately).

* With Automatic Drain, max temp is 120°F (49°C) and pressure range is 15 to 175 PSIG (to 12 bar)

† Useful Retention refers to volume below the quiet zone baffle.

Specifications

Bowl Capacity	4.0 Ounces
Filter Rating	5 Micron
Gauge Port	1/4 Inch
Port Threads	1/2 Inch
Pressure & Temperature Ratings –	300 PSIG Max (20.7 bar)
	40°F to 150°F (4°C to 66°C)*
Useful Retention†	1.7 Ounce
Weight	2.42 lb. (1.09 kg)

Materials of Construction

Body	316 Stainless Steel
Bowl	316 Stainless Steel
Drain	316 Stainless Steel
Filter Elements (Type A)	Polyethylene
Element Holder / Deflector / Bonnet	Acetal
Diaphragm and Seals	Fluorocarbon
Valve Assembly and Bottom Plug	316 Stainless Steel
Springs	316 Stainless Steel
Knob	Polypropylene

SL2 Lubricator – Standard

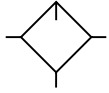

Features

- Stainless Steel Construction handles most corrosive environments.
- Meets NACE specifications.
- High Flow: 1/2" – 100 SCFM[§]

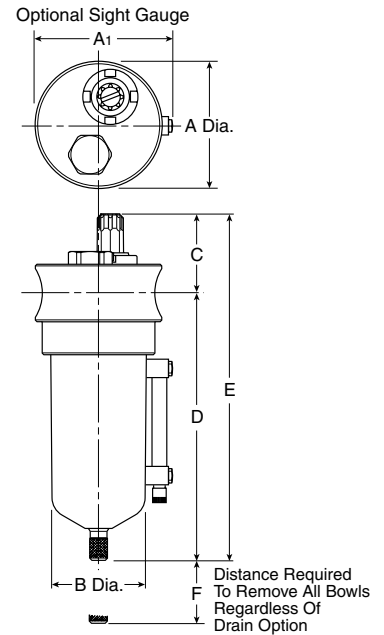

Port Size	NPT	BSPP
1/2"	SL2-04-LLV0	SL2-C4-LLV0

SL2 Lubricator Dimensions		
A 2.38 60 mm	A₁ 2.50 64 mm	B 1.75 44 mm
C 1.81 46 mm	D 5.00 127 mm	E 6.81 173 mm
F 3.50 89 mm		

Standard part numbers shown, for other models refer to ordering information below.
[§] SCFM = Standard cubic feet per minute at 90 PSIG inlet and 5 PSIG pressure drop.

Ordering Information

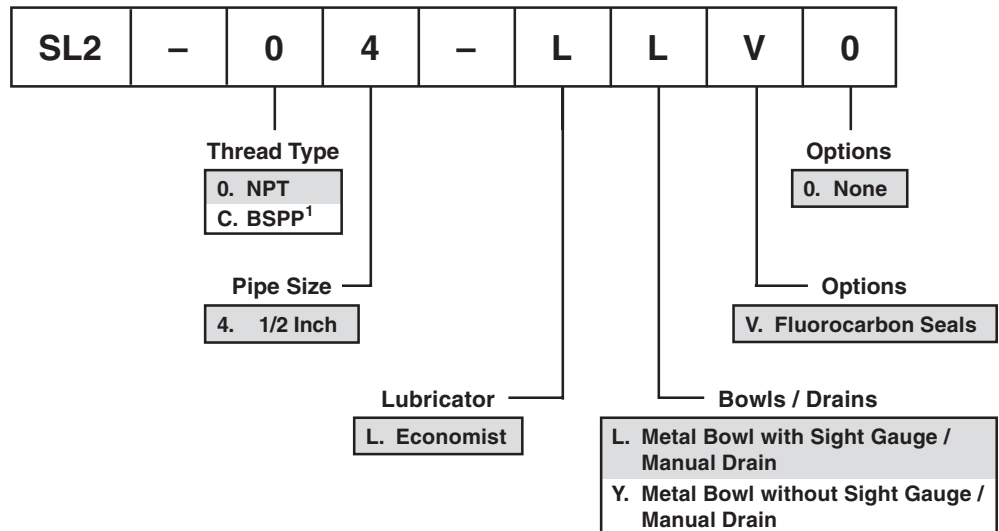

¹ ISO, R228 (G SERIES)

NOTE: Shaded = "Most Popular".

Operation

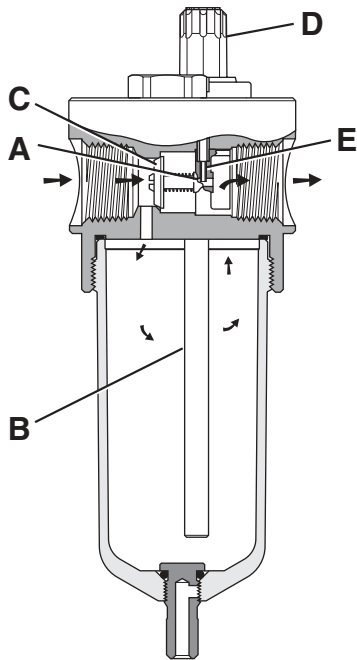

Air flowing through the unit goes through two paths. At low flow rates the majority of the air flows through the Venturi section (A). The rest of the air opens the check valve (C). The velocity of the air flowing through the Venturi section (A) creates a pressure drop. This lower pressure allows the oil to be forced from the reservoir through the pickup tube (B) and travels up to the metering screw (D). The rate of oil delivery is then controlled by adjusting the metering screw (D). Oil flows past the metering screw (D) and forms a drop in the nozzle tube (E). As the oil drops through the dome and back into the Venturi section (A), it is broken up into fine particles. It is then mixed with the air flowing past the check valve (C) and is carried downstream. As the air flow increases the check valve (C) will open more fully. This additional flow will assure that the oil delivery rate will increase linearly with the increase of air flow.

Technical Information

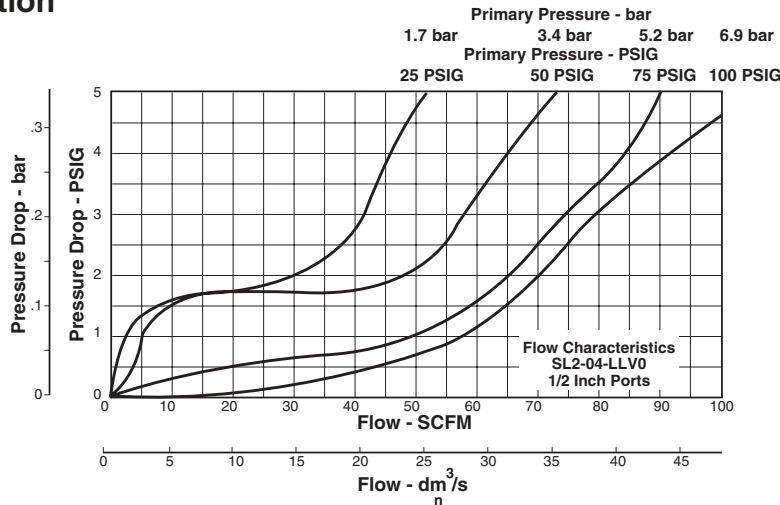

SL2 Filter Kits & Accessories

- Drain Kit – Manual Drain SRP-96-008
- Liquid Level Sight and Gauge Kit SRP-96-026
- Pipe Nipple – 1/2" 316 Stainless Steel SRP-96-010
- Sight Dome / Metering Screw Kit SRP-96-025

Specifications

- Bowl Capacity 4.0 Ounces
- Port Threads 1/2 Inch
- Pressure & Temperature Ratings – 0 to 300 PSIG (0 to 20.7 bar)
 40°F to 150°F (4°C to 66°C)
- Useful Retention 4 Ounces
- Weight 1.9 lb. (0.85 kg)

Materials of Construction

- Body 316 Stainless Steel
- Bowl 316 Stainless Steel
- Drain (Manual) 316 Stainless Steel
- Seals Fluorocarbon
- Sight Dome Nylon